

Installation Operation Maintenance Manual

Simplex Organic Scavenger With 5600, 2510 or 2750 Series Downflow Brining Valve

Models

50 lit
75 lit
100 lit
150 lit
200 lit
250 lit

ORGANIC SCAVENGER Simplex Series O & IM

1.0	GENERAL NOTES	4
2.0	THE SCAVENGING PROCESS.....	5
2.1	IN SERVICE.....	5
2.2	REGENERATION.....	5
2.3	THE REGENERATION PROCESS.....	6
2.4	METER CONTROL OF REGENERATION INITIATION.....	6
2.5	TIME CLOCK CONTROL OF REGENERATION INITIATION	7
3.0	UNPACKING AND PARTS IDENTIFICATION	8
3.1	BASIC PACKAGES.....	8
3.2	UNPACKING NOTES	8
3.3	MISSING OR DAMAGED GOODS.....	8
4.0	TEMPORARY STORAGE	8
5.0	DESCRIPTION OF PLANT COMPONENTS.....	9
5.1	SCAVENGER VESSEL AND INTERNALS	9
5.2	CONTROL VALVE	9
5.3	REGENERATION CONTROLLER AND TRANSFORMER	9
5.4	BRINE SYSTEM.....	10
6.0	PRE-INSTALLATION	11
6.1	MECHANICAL.....	11
6.1.1	Foundation/Drainage.....	11
6.1.2	Operating Space	11
6.1.3	Incoming Water.....	11
6.1.4	Pipework	12
6.1.5	Water Supply Company Requirements.....	12
6.2	ELECTRICAL	12
7.0	ASSEMBLY/INSTALLATION	14
7.1	MECHANICAL	14
7.1.1	Simplex Models	14
7.1.2	Charging the Resin.....	14
7.1.3	Assembling the Control Valve.....	15
7.1.4	Attaching the Control Valve	15
7.1.5	Brine System	15
7.1.6	Pipework	15
7.1.7	Storage tank ball valve.....	16
7.1.8	Drains and overflow connections.....	16
7.2	ELECTRICAL	17
7.2.1	Mains Supply	17
7.2.2	Transformer.....	17
8.0	COMMISSIONING	18
8.1	INTRODUCTION.....	18
8.2	CONTROLLER SETTING.....	18
8.2.1	Setting the Time of Day	18
8.2.2	Site programming.....	18
8.3	BRINE SYSTEM.....	19
8.3.1	Salt Tank Filling	19
8.4	PRE-SERVICE FLUSH AND REGENERATION	19

ORGANIC SCAVENGER Simplex Series O & IM

9.0	OPERATION	21
9.1	NORMAL OPERATION.....	21
9.2	REFILLING WITH SALT	21
9.3	MANUAL REGENERATION	21
9.4	BY-PASSING THE SCAVENGER	21
9.5	TEMPORARY SHUT-DOWN.....	22
9.6	CHANGES IN INCOMING WATER	22
9.7	ROUTINE MONITORING.....	22
10.0	FAULT FINDING AND RECTIFICATION	24
10.1	NO FLOW TO SERVICE.....	24
10.2	POOR TREATED WATER QUALITY	24
10.3	NO REGENERATION	25
10.4	UNSATISFACTORY CAPACITY BETWEEN REGENERATIONS	25
11.0	WARRANTY AND SERVICE	26
11.1	AFTER SALE WARRANTY	26
12.0	ENGINEERING DATA.....	27
12.1	PROCESS AND OPERATING DATA	27
13.0	Immediate regeneration.....	29
14.0	Drawings	30
14.1	Installation Layout.....	30

1.0 GENERAL NOTES

These instructions cover the 5600, 2510 & 2750 Range of Simplex Organic Scavengers, which includes models ranging in size from 50-250 litres resin volume.

It is recommended that these instructions are read throughout before commencing any work on the unit, particularly if you have no previous experience of installing and using a scavenger.

The installation of a scavenger is very straightforward, and the only adjustments to be made to the controller program are setting the time of day and water hardness as detailed in Section 8.2.2. However we have tried to make these instructions as comprehensive as possible to answer any queries you may have about the functioning of your scavenger.

This scavenger will require salt for regeneration. We recommend the used of proprietary 'pellet' or 'tablet' salt.

In the appendix to this manual is the original valve manufacturer's handbook. This is written for American customers and has a number of small differences in the setting up instructions from those used in Europe. In the event of confusion, refer to the data in this manual rather than in the valve manufacturer's handbook!

2.0 THE SCAVENGING PROCESS

Organic discolouration in water is caused by the presence of dissolved humic acids which are long chain complex organic molecules. In order to overcome the problems associated with these molecules, the humic must be removed. This process is called 'Scavenging'. One means of removing the organic molecules is to exchange them for soluble salts. This technique is known as 'Ion Exchange Scavenging'.

2.1 IN SERVICE

In order to scavenge the water, it is passed through a bed of Ion Exchange resin beads which are contained inside a vertical cylindrical vessel. these beads are made of a synthetic material, and are usually amber or dark brown in colour and between 0.5 and 1.0 mm in diameter.

As the water flows down through the resin, the humic acid molecules in the feed water are progressively exchanged for Chloride, with the result that the water which flows out of the unit contains Chloride ions instead of humic acids.

The Ion Exchange resin does not have an unlimited capacity for exchanging humic acids, so to keep the exit water fully treated it is necessary to periodically 'Regenerate' the resin to restore its capacity to scavenge the water.

2.2 REGENERATION

The scavenging process can be reversed if a strong solution of Sodium Chloride (i.e. Common salt dissolved in water -'brine') is passed through the resin.

The high concentration of Chloride allows it to exchange for the humic acids held on the resin, and these are then carried away to drain. The resin is left full of Chloride to enable it to soften water again. Depending on the type of humic acid removed, it may also be necessary to periodically regenerate the unit with Caustic Brine where a small amount of Caustic Soda added to the brine to assist in removing organic molecules from the surface of the resin. 1 kg of Caustic per 50 litres of resin should be added tot eh brine tank before the start of a regeneration.

2.3 THE REGENERATION PROCESS

The regeneration process consists of four stages:-

Backwash - Water flows upwards through the resin bed, and out to a drain. As it does so, it loosens the ion exchange beads, removes any resin 'fines' (i.e. small pieces of broken beads etc.) and cleans off any particles of dirt or pipework corrosion products which may have accumulated during the service cycle.

Brine injection/Displacement Rinse - During the first part of this stage, the concentrated salt -solution is drawn from the salt storage tank, blended with water to reduce the concentration to the correct level, and passed up through the resin. When the required quantity of brine has been drawn in, the water flows alone to push the remaining brine through the resin at the correct rate, and ensure that all the resin sees the right amount of regenerant.

Fast Rinse - This follows the brine draw/displacement rinse, and entails rinsing away the residual brine and humic acids from the resin and re-packing the resin bed down. This is done down with water flowing through the resin in the direction of service.

Salt Tank Refill - Following the fast rinse, a quantity of water sufficient to dissolve the correct amount of salt for the next regeneration is returned to the salt tank. When this has finished, the unit automatically returns to service.

2.4 METER CONTROL OF REGENERATION INITIATION

A water meter is installed in the outlet from the scavenger, to measure the volume of water which passes to service. This meter drives a turbine, the movement of which is measured by a magnetic sensor which sends signals to the regeneration controller. The controller microprocessor uses this information to calculate when the unit should be regenerated. Every night, at 2 am (for example), the volume of water used in the preceding days is compared to the capacity of the scavenger. The computer then assesses if the resin has enough capacity left to supply the next day's use, and if not, starts the regeneration.

2.5 TIME CLOCK CONTROL OF REGENERATION INITIATION

Time clock configuration valves initiate regeneration at a pre-set time after a pre-set number of days. Both the time of day for regeneration and the frequency of regeneration are adjustable.

3.0 UNPACKING AND PARTS IDENTIFICATION

3.1 BASIC PACKAGES

The scavenger will be delivered in a number of packages which include a glassfibre reinforced pressure vessel, a control valve, a brine tanks, two or more 25 litre bags of resin and a funnel to fill the vessel

3.2 UNPACKING NOTES

The unpacking of the scavenger is quite straightforward, and there are no 'hidden' items. It is advisable to keep the packages sealed until such time as they are used, to prevent dust or water entry.

Care should be taken in lifting the scavenger or its parts out of their cartons. It is advisable to lay large cartons on their side and slide out the scavenger or parts prior to standing them up.

3.3 MISSING OR DAMAGED GOODS

Immediately on receipt of the goods, it is advisable to check that all items ordered have been received. If you have any doubt that goods have been supplied as requested, please contact your supplier immediately. If any items are missing or damaged, the carrier and your supplier must be notified in writing within 3 days of receipt if a claim is to be made.

4.0 TEMPORARY STORAGE

If installation is not to start immediately after delivery, the equipment should be stored in a clean dry area, where it will not be damaged, or be subjected to temperatures below freezing.

5.0 DESCRIPTION OF PLANT COMPONENTS

5.1 SCAVENGER VESSEL AND INTERNALS

The pressure vessel which contains the ion exchange resin is made from a fibreglass/epoxy resin outer layer surrounding an inner, seamless shell made from Polyethylene. The vessel has a threaded hole at the top, of 2.5 inch nominal diameter, into which the control valve fits.

All vessels are equipped with a single filter distribution system. This is attached to a central riser tube, which is connected to the control valve, and passes water into and out of the resin bed.

5.2 CONTROL VALVE

The control valve is mounted on top of the vessel, and directs the water flow in and out of the resin bed during the service and regeneration cycles. The body of the control valve is made from glass reinforced Noryl.

The valve carries out its various functions by rotating a cam that drives a piston through a series of seals and ports. Depending on the position of the piston in the seal stack, the different functions of the valve will take place

5.3 REGENERATION CONTROLLER AND TRANSFORMER

The regeneration controller is attached to the valve, and is contained in a plastic housing.

The controller is powered by 24v AC electricity, and a separate, wall mounted transformer is connected to the valve to reduce normal mains voltage down from 240v so that all the electrical supply in and around the control valve runs at a safe 24v.

5.4 BRINE SYSTEM

The brine system consists of a moulded polyethylene tank into which the brine well and brine pick up are assembled. The tank forms the salt storage container.

The brine pick-up tube is connected to the pipe from the control valve which sucks the brine from the tank. At the bottom of the brine pick-up tube is an air check valve. This serves to prevent air entering the valve when all the brine has been drawn in. Air in the system could cause spurting and 'hammering' at the taps or outlets.

6.0 PRE-INSTALLATION

6.1 MECHANICAL

6.1.1 Foundation/Drainage

The scavenger will not require any special foundations, provided that a firm, level area which is capable of supporting the working weight is available. (See Engineering Data, Section 12.2)

Unwanted water from the regeneration process must flow to drain, and so an open drain or gully, capable of passing the necessary flow is required (see Process and Operating Data, 12.1, for relevant flows). The total flow of water to drain depends on site conditions, but will be approximately 6 times the resin volume. The drain may be at a level no higher than 500mm above the scavenger valve.

A second drain is required for the brine tank overflow. This is a safety drain which will only discharge water if there is a malfunction in the control valve. Where possible this should be installed through an outside wall like a cistern overflow, where it will give a visual indication of any failure.

6.1.2 Operating Space

The space occupied by the scavenger can be found in the Engineering Data (Section 12.2).,

Access will be required to refill the brine tank, and to carry out adjustments or maintenance on the equipment. It is therefore recommended that a minimum of 500mm clearance be allowed in front of the unit for this purpose.

6.1.3 Incoming Water

The raw water to be fed to the scavenger must comply with the following:-

1. Available at all times at a flow equal to the required service flow or greater, and
2. At a pressure between 1.7 and 5.5 bar
3. Temperature between 0 and 50°C
4. Suspended solids less than 1 ppm

ORGANIC SCAVENGER Simplex Series O & IM

5. Iron less than 0.2 ppm, Manganese less than 0.1 ppm, Free Chlorine less than 1 ppm if temperature is less than 15°C, less than 0.3 ppm if temperature higher (up to 30°C)

6.1.4 Pipework

Pipework to be connected to the scavenger should not have an excessive amount of hardness scale deposit. Piping that is heavily built up with scale (or Iron deposits) should be replaced.

Make sure that the pipework can be connected to the scavenger in such a way as to impose no stresses on the control valve, and that it is properly aligned and supported.

A system for the complete by-passing and isolation of the scavenger should be installed (see Section 7.1.6).

6.1.5 Water Supply Company Requirements

It is essential that if the equipment is to be connected directly to a mains water supply, the local bylaws must be adhered to. These cover both plumbing and the prevention of backflow into the mains. If there is any doubt, the local water inspector should be consulted, but in general, the installation of a 'Double check valve assembly' conforming to BS6282 part 2 will be required in the feed pipework to the scavenger.

If the pressure available from the mains is not adequate it will be necessary to install a booster pump arrangement. Such a system would be covered by additional bylaws, and the water storage tank needed must comply with these.

6.2 ***ELECTRICAL***

A continuous supply of 24v, 5 VA is required by the scavenger. A 240v transformer with an output of 9.6 VA is provided, which should be connected to an uninterrupted mains supply, which is separately 1 Amp fused, and does not have any additional switch.

It is recommended that the transformer be attached to a nearby wall, within 500 mm of the scavenger in an area free from water spray or excessive heat or condensation.

A plug is not provided with this scavenger since the cable should be connected to fused spur outlet. However if that is not possible then a plug should be fitted to the cable with a 1 amp fuse. The socket used

ORGANIC SCAVENGER Simplex Series O & IM

should be un-switched to prevent the scavenger from being inadvertently turned off.

7.0 ASSEMBLY/INSTALLATION

7.1 MECHANICAL

Check all the items against the parts list and shipping documents, and ensure you have them all before starting work. In addition to the scavenger you will require installation materials and basic tools, (i.e., spanners, screwdrivers etc., and PTFE tape)

7.1.1 Simplex Models

Assembling Vessel, Riser Tube and Internals

Simplex units are shipped as pre-assembled components to reduce the risk of transit damage. These need to be assembled on site. Open the carton containing the pressure vessel and remove it. Check that the vessel has not been damaged in transit. Pay particular attention to the vessel top hole threads, as this is where the valve will seal. Check that there is no dirt or swarf inside.

Riser Tube/Bottom Filter

This comprises a length of pipe (the 'riser tube') to one end of which is glued a moulded screen. The other end is fitted into the bottom of the control valve. To make sure the riser fits properly, and there is no leakage, it will be supplied to the correct length prior to despatch.

7.1.2 Charging the Resin

The ion exchange resin is supplied in 25 litre bags plus a part bag if applicable. All models will be supplied with exactly the right quantity of resin. Two different, but fully compatible resins are used to optimise the efficiency of the resin with a wide range of organic loadings in the raw water. It is important that only the correct volume of resin is put into the vessel or the system will not function properly. (See **Section 12.1.2** for data)

Place the vessel in its final location - once filled with resin and water they should not be moved. Fill the vessel about 1/5 full with clean water. The riser is 45 mm shorter than the internal height of the vessel so in order to keep it centrally located and prevent resin falling inside the riser, and 'extender/cover' is provided to be slipped over the end of the riser when filling with resin. This must be carefully removed without

ORGANIC SCAVENGER Simplex Series O & IM

disturbing the riser prior to fitting the control valve. Carefully open the resin bags and pour the resin into the vessel, using the funnel provided, keeping the riser tube central and upright. Take great care not to spill resin on the floor. If any is spilt, make sure it is swept up immediately, as it is very easy to slip on it. Wash away any loose resin from the threads of the vessel or adapter collar. Remove the riser extender cover and check that the top of the riser is still correctly located

7.1.3 Assembling the Control Valve

Carefully remove the control valve from its packing, and check that all parts are present. Fit the top filter/distributor to the valve. This is a 'snap' bayonet fit.

7.1.4 Attaching the Control Valve

Carefully fit the control valve on to the vessel, taking care to ensure that the riser tube locates correctly into the valve base through the top distributor, and that the threads are not crossed. Also take care to make sure that the 'O'rings are properly seated and not pinched.

7.1.5. Brine System

Move brine tank into position and connect the outer port of the bulk head union to the brine draw connection on the valve using the 3/8" tubing. Make sure that this connection is also tight to stop air leaking in.

If brine draw tubing is adjusted for length during installation, ensure that brass tubing inserts are refitted into tubing end prior to connecting into brine tank and control valve.

7.1.6 Pipework

Pipework should be assembled incorporating the features shown in the Installation Diagram, Section 14.1. It is essential that inlet and outlet isolating valves and a by-pass valve are provided, and that the water main is protected by a double check valve where appropriate (see Local Water Bye-laws).

In domestic premises it is recommended that a hard water supply is still used for drinking water (see General Notes Section 1.0).

ORGANIC SCAVENGER Simplex Series O & IM

Pipework can be constructed from any normally acceptable material (Copper, Galvanised, Plastic), provided it is properly supported and aligned. Ensure that the pipe is sufficiently large to accommodate the flow of water required, making due allowance for the pressure drop between the scavenger and the point of discharge of soft water.

NOTE: IF BRAZED OR SOLDERED FITTINGS ARE TO BE USED, THE PIPEWORK MUST BE DISCONNECTED FROM THE VALVE DURING HEATING AND COOLING. EXCESS HEAT CAN CAUSE PERMANENT DAMAGE TO SOME OF THE VALVE COMPONENTS.

The inlet and outlet pipework should be connected to the horizontal, rear facing connections on the rear of the valve manifold (1" BSP Female) (see Fig 1 in Section 14.1).

7.1.7 Storage tank ball valve

Conventional ball float valves pass water at a slow trickle into storage tanks and cisterns when they are shutting off. Trickle flow is not recommended for satisfactory functioning of a scavenger since channelling can occur through the resin bed and the meter may not accurately monitor very low flows. It is therefore recommended that main storage tanks for softened water should have the ball valve replaced with a servo type valve such as a Torbeck or Fluidmaster which permit full flow until they close off. These are inexpensive and are a direct replacement for the more common brass ball float valves.

7.1.8 Drains and overflow connections

Connect the overflow fitting on the brine tank to a suitable drain, using flexible or rigid tubing. Make sure that there is a clear gap of approximately 50 mm between the end of the tube and the top of the drain tundish or gully edge.

The drain connection from the valve is a 1/2" hose spigot. Flexible tube should be run from this spigot to a drain capable of taking the maximum flow in regeneration (see Section 12.1), and leaving a similar gap above the drain edge. The drain must not be higher level than the 500mm above the control valve and preferably should have an air break at the same height as the control valve. A standard washing machine upstand is quite suitable for this.

7.2 ELECTRICAL

Electrical installation is very straightforward, but should still be carried out by a competent electrician, and must conform to the appropriate standards of safety.

7.2.1 Mains Supply

The mains supply should be through a separate, switched supply, fused and earthed in accordance with Institute of Electrical Engineers Regulations. Current rating should be 1 Amp.

7.2.2 Transformer

A safety transformer is provided to reduce the voltage to 24 Volts to operate the controls.

This should be attached to a convenient wall, within 500mm of the scavenger. **DO NOT SWITCH ON THE ELECTRICAL SUPPLY AT THIS STAGE** See Fig 3 in Section 14.2

8.0 COMMISSIONING

8.1 INTRODUCTION

It is recommended that the commissioning of the plant is undertaken by a trained service engineer, who will be able to put the plant into service quickly, and most efficiently. However, if the services of an experienced engineer are not available, following the steps outlined below will result in the system being properly commissioned.

8.2 CONTROLLER SETTING - Site programming mode

All controller settings will require the valve to have a mains supply switched on. The valve must not be regenerating when controller settings are adjusted.

8.2.1 Setting the Time of Day

Press and hold the red button on the front of the timer assembly. Turn the timer wheel until the actual time of day is opposite the time of day pointer. Release the red button .

8.2.2 Site programming - Setting the regen days or capacity and regeneration override.

The days that a regeneration is required must be set using the skipper wheel. Rotate the skipper wheel until the number 1 is at the red pointer. Set the regeneration days by sliding the metal tabs on the skipper wheel outwards. Each tab represents 1 day.

8.3 BRINE SYSTEM

8.3.1 Salt Tank Filling

Place approximately 100 mm depth of water in the bottom of the cabinet. Fill with pellet salt (recommended) until the cabinet is full or with granular salt until it is 3/4 full.

Overfilling the cabinet with granular salt can result in an overflow of brine. This cannot happen with pellet salt which is why it is recommended.

Under no circumstances use cooking salt or Pure Vacuum Dried (PVD) salt to fill the cabinet as either of these will damage the resin and the internal components of the regeneration valve and brine draw system.

8.4 PRE-SERVICE FLUSH AND REGENERATION

Set the manual isolating valves so that water will by-pass the scavenger. Turn on the main water supply. Open a treated water tap close by and let the water run for a few minutes to flush out any debris or foreign matter from the pipework system.

Turn on the power supply to the valve.

Remove the dust cover from the control valve and ensure that the meter cable is not plugged into the meter on outlet of the valve. Swing 'open' the timer assembly on the left of the valve by pulling on its right hand edge. When the piston is in the backwash position of the regeneration cycle (fully in) , turn off the power supply.

Turn on the power supply. The drive motor on the left of the timer will run and will start to drive the piston. This will take several minutes. Turn off the power supply.

Slowly open the water inlet valve. Air will be expelled from the drain line, followed by water once the vessels are filled with water. Open the inlet valve fully to allow water to run to drain for 4-5 minutes.

Turn on the power supply and index the regeneration knob to the 'brine' position - the microswitch is in the first (long) gap in the bank of pins. Water/brine will be drawn in from the brine tank, and water will trickle slowly down the drain line.

When the piston has stopped moving, index to the rapid rinse section - second bank of pins - and again wait for the piston to stop moving. Water

ORGANIC SCAVENGER Simplex Series O & IM

will run quickly down the drain line.

Index the knob to the brine refill section - second (short) gap in the pins - and wait for the piston to stop moving. Water will be refilled into the brine tank. Finally, index the knob to the 'home' position past the last pair of pins (inner microswitch drops into the indent in program wheel) and wait for the piston to stop moving.

'Close' the timer so that the support leg snaps into the backplate. Adjust the capacity of the softener if necessary using the reference sheet attached. The units used on the dial are cubic metres (m³). Replace the valve dust cover. Plug the meter cable back into the meter on the outlet of the valve. Open the outlet valve (if fitted) and test the water output from a downstream tap.

9.0 OPERATION

9.1 NORMAL OPERATION

Operation is completely automatic, with regeneration being initiated whenever required by the valve controller.

9.2 REFILLING WITH SALT

Since salt is used in the regeneration process, the level of salt in the brine tank will fall after each regeneration. It should not be allowed to fall below 75 mm above the bottom of the cabinet. When the low level is approached (or more often, as a routine) the cabinet should be refilled to the top with pellet salt or 3/4 filled with granular salt.

The approximate capacity of the cabinet for salt is shown in Section 12.1.

9.3 MANUAL REGENERATION

There can be occasions during the life of equipment such as softeners when the original design basis is not applicable. For example, after a shutdown period, the demand for soft water may far exceed the design flow rate for a short period. Another possibility is that the Water Service Plc finds it necessary to change to a supply which is much harder than that normally received. It will then be necessary to give the unit an additional regeneration to ensure that soft water continues to be available to service.

This additional regeneration is initiated manually.

Remove the timer cover and index the program wheel knob approximately 6mm clockwise until a loud click is heard. Regeneration will proceed automatically immediately. It will be a few seconds until regeneration water starts to pass to drain.

9.4 BY-PASSING THE SCAVENGER

There may be occasions when it is desirable to by-pass the scavenger, to allow hard water to go to service, or if the scavenger is for some reason not performing properly.

To do this, open the by-pass isolating valve and close the scavenger outlet isolating valve (see Installation Diagram, Fig 3 in Section 14.2).

ORGANIC SCAVENGER Simplex Series O & IM

The scavenger can still be safely regenerated with the valves in this position. If for any reason, it is desired to completely isolate the scavenger, it will be necessary to close the inlet isolating valve as well.

9.5 TEMPORARY SHUT-DOWN

The scavenger can be left indefinitely without use. During periods of low or minimal water use, for example during vacation absences, the valve controller will automatically regenerate the resin at the frequency set in the regeneration override.

If the scavenger needs to be taken out of service for some time for any other reason, it is recommended that one or two simple procedures be undertaken to ensure the return to operation is as smooth as possible.

1. The unit should be left regenerated.
2. The electrical supply should be turned off
3. The inlet and outlet manual isolating valves should be closed.
4. The valve should be drained of water if there is the possibility of the system freezing.

On restart, it will be necessary to reset the 'time of day'. It is also recommended that the unit be regenerated again before being put into service.

9.6 CHANGES IN INCOMING WATER

There is a much greater tendency these days for the Water supply Plc to use water from more than one source. It is unlikely that two sources will have similar chemical composition, and so when this happens the raw water being fed to the unit may also change. It is suggested that routine monitoring be undertaken to check whether this is the case (see 9.9). If variation greater than 5% is found, it will be necessary to check whether the settings for regeneration need changing. Resetting is the same as setting.

9.7 ROUTINE MONITORING

The following recommendations are made to help the user of the scavenger confirm that it is performing as required, and to give early warning of possible problems. The operation of the scavenger is completely automatic, and should not require adjustment (except as above).

Weekly

ORGANIC SCAVENGER Simplex Series O & IM

Check the treated water quality.
Inspect the level of salt in the salt tank and refill if necessary.

Monthly

Check raw water quality, and record. Compare with original quality data and adjust volume capacity setting if required (see Section 13.1).

Annually

Inspect and clean/replace as necessary the brine injector, piston and the internal seals. This should be performed by a competent engineer familiar with Fleck valves.

10.0 FAULT FINDING AND RECTIFICATION

Modern water scavengers are extremely reliable and unlikely to give any problems if they are installed and operated correctly.

10.1 NO FLOW TO SERVICE

Check mains pressure is above 1.7 bar.

Check inlet and outlet isolating valves are open.

Check service outlet valve is open.

Check pressure drop across resin. If excessive, resin may be fouled, or internals blocked. Initiate a caustic regeneration. If this does not free up the resin the scavenger will need to be inspected and serviced by a competent engineer.

10.2 POOR TREATED WATER QUALITY

Check manual by-pass closed.

Check blending valve has not been opened or adjusted.

Check salt level in salt tank. Refill if necessary.

Trickle flow through conventional ball valve in storage tank. Replace with Torbeck or Fluidmaster servo valve.

Check raw water pressure above minimum. If flow is less than minimum, channelling of water can occur in resin, which results in inadequate treatment.

Check injector strainer and injector not blocked (see Appendix for drawings). Clean if necessary.

Check brine pick-up screen not blocked. Clean if necessary.

Check brine line not split. Replace if necessary.

Check raw water quality, and then check if controller setting is correct for this quality.

10.3 NO REGENERATION

Check electrical supply, fuses etc. satisfactory.

Check control head motor runs, by initiating a manual regeneration, and listening for drive motor gently 'ticking' as it advances between cycles. Replace if necessary.

Check meter running freely (if fitted) indicated by running a treated water outlet and watching the flow indicator and 'volume remaining' reading on the display count down at the same rate as the water flow.

10.4 UNSATISFACTORY CAPACITY BETWEEN REGENERATIONS

See Section 10.2.

Check condition of resin. It may have become fouled, inhibiting the regeneration process. If fouled, it should be cleaned or replaced.

Check incoming water for presence of Chlorine. If high, the resin may have been degraded.

Check raw water pressure. Too high pressure may mean the brine draw stage of regeneration is not effective

11.0 WARRANTY AND SERVICE

11.1 AFTER SALE WARRANTY

Your scavenger is covered by a parts warranty for a period of one year from installation.

Should you have any problems with your scavenger or require routine service, please contact your supplier.

12.0 ENGINEERING DATA

12.1 PROCESS AND OPERATING DATA

MODEL		50 L	75	100 L	150 L	200 L	250 L
PARAMETER	UNITS						
Max. Service Flow	M3/hr	0.78	1.17	1.56	2.34	3.12	3.9
Salt used per regeneration	kg	12	18	24	36	48	60
Regeneration Time	mins	82	82	106	108	124	134
Resin Volume	litres	50	75	100	150	200	250
Salt Storage Capacity	kg	160	160	300	400	500	750
No of Regens Salt stored	-	13	8	12	11	10	12

IMPORTANT NOTES

Much of the data quoted in the above table is affected by the inlet pressure, and so should be regarded as nominal only.

Total flow to drain will be similarly affected and is therefore not quoted, but will be about 6 times the resin volume.

ORGANIC SCAVENGER Simplex Series O & IM

12.2 ENGINEERING DATA

12.2.1 5600 and 2510 Series Water Scavengers 50-150litre

MODEL		50 L	75 L	100 L	150 L	200 L	250 L
PARAMETER	UNITS						
Diameter of vessel/valve	mm	270	330	370	406	534	534
Height to top of valve	mm	1590	1590	1984	1988	2038	2038
Diameter of brine tank	mm	480	480	700	840	880	880
Height of brine tank	mm	1040	1040	950	900	1100	1250
Inlet Conn.	ins BSPF	1.0	1.0	1.0	1.0	1.0	1.0
Outlet Conn.	ins BSPF	1.0	1.0	1.0	1.0	1.0	1.0
Drain Conn.	ins	1/2	1/2	1/2	1/2	3/4	3/4
Brine Tank Overflow Conn.	ins	3/4	3/4	3/4	3/4	3/4	3/4
Delivered Wt.	Kg.	58	85	115	170	225	280
Valve		50-150 2510, 200 & 250 2750					
Electrical							
Power	v	240					
	Hz	50					
	V/A	1.2					

MAXIMUM OPERATING PRESSURE 5.5 Bar MINIMUM OPERATING
 PRESSURE 1.7 Bar MAXIMUM OPERATING TEMPERATURE 50.0C
 HEADROOM - Allow 100 mm greater than overall height.

13.0 Immediate regeneration.

Remove the timer cover and index the program wheel knob approximately 6mm clockwise until a loud click is heard. Regeneration will proceed automatically immediately. It will be a few seconds until regeneration water starts to pass to drain.

14.0 Drawings

14.1 Installation Layout

Fig 1 General Installation Layout 5600/2510/2750 Simplex Scavengers

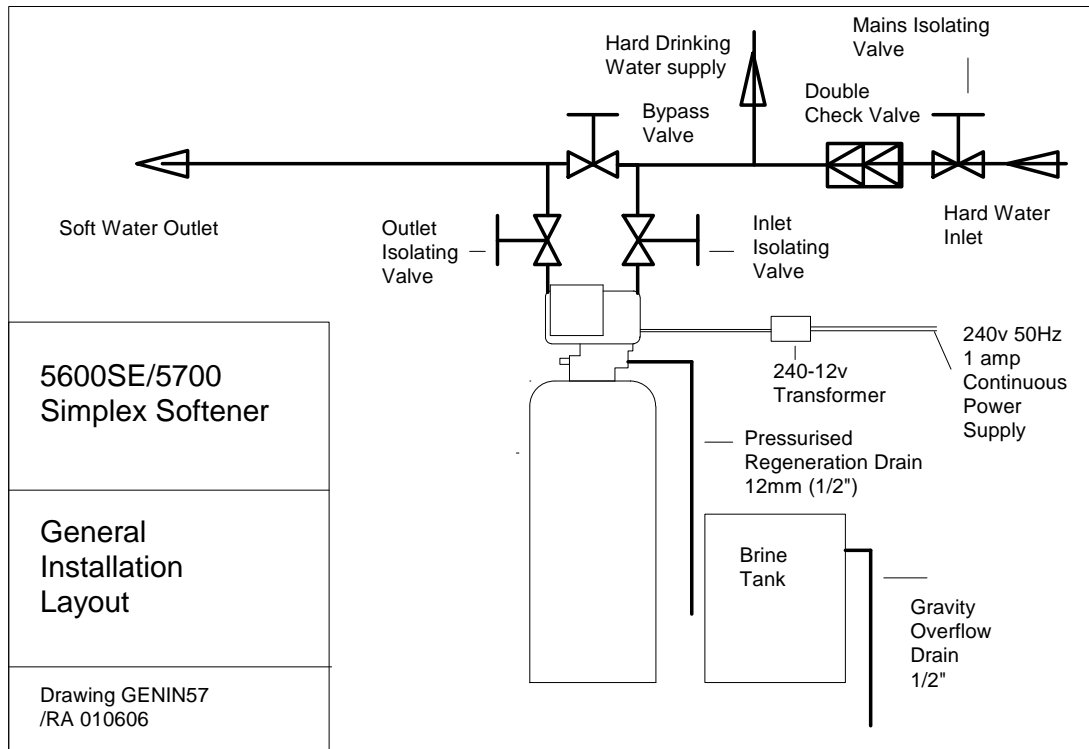

Manufacturer's Declaration of Conformity

We the undersigned

EURAQUA UK, HITCHIN, ENGLAND

Certify that the product

*type: **SIMPLEX ORGANIC SCAVENGER WITH FLECK 5600, 2510, 2750
24 VOLT AC VALVE***

*has been designed and manufactured in accordance with the
specifications of the following:*

Directive

Machinery Directive 89/392/EEC
Low Voltage Directive 73/23/EEC
EMC-Directive 89/336/EEC

Standard

EN 292-1, EN 292-2
EN 60 335-1
EN 55 014



RT Adam
Director

Hitchin, England 01/01/06
Issue place & date